



FM 4

WARNING!

To ensure a proper and safe use of the meter it's necessary to read and follow the instructions and warnings contained in this manual. An improper installation or use of the meter may cause damage to object or people. Keep this manual in a safety place. This meter has been designed for diesel only use: don't use it for other chemical or inflammable substance or food. Be aware that this device is not suitable to measure product for resale.

GENERAL INFORMATION

FM4 is mechanical flow meter with nutating disk, designed to allow a precise measurement of Diesel oil. The nutating disk of the metering chamber, which is set in motion by the fluid itself, drives the gear train located in the cover of the meter body, which transfer the motion to the 4 digits meter. The meter is equipped with a no-resettable litre totaliser and a batch register which can be reset by means of a knob, whose unit digit is provided with marks of the readout of the tenths of a litre.

Technical data

<i>Flow rate (range)</i>	<i>20 - 120 l/min.</i>
<i>Meter mechanism</i>	<i>Nutating disk</i>
<i>Read out system: subtotal / total</i>	<i>4 digits (9999) / 8 digits (99999999)</i>
<i>Operating pressure</i>	<i>max. 3.5 bar</i>
<i>Accuracy after calibration / Repeatability</i>	<i>+/- 1% / +/- 0.2%</i>
<i>Treathed connectors</i>	<i>1" BSP/NPT</i>
<i>Body material</i>	<i>Aluminium</i>
<i>Dimensions (bxhxp) / Weight</i>	<i>240x165x170 mm / 1.8 Kg</i>

INSTALLATION

The meter FM4 can be installed in any position, on rigid pipeline or flexible hoses, directly on pumps or on tanks.

The meter flow direction is fix and indicated by an arrow. The meter is supplied in the standard configuration (A). The meter and the cover can be rotated by 90° to 90°, in respect to the body in order to carry out the different configuration shown on the side. The meter body is equipped, in the back side, with 4 blind holes which can be threaded with M5 self-threading screws for a possible fastening.

WARNING! If solid particles (i.e. sand, etc.) enter into the measuring chamber, the correct working of the nutating disk may be affected: it is always recommended filter the fluid by installing a filter on the meter inlet.

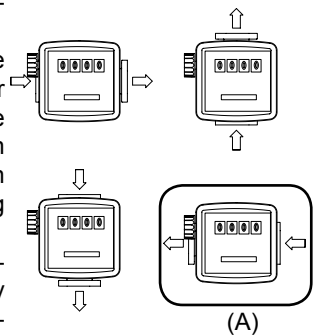

CALIBRATION

FM 4 is pre-calibrated in factory to be used with Diesel oil. As specific operating conditions may affect the meter accuracy, a recalibration should be carried out after the installation has been completed. A new calibration is necessary each time the meter is disassembled for maintenance operations.

Meter Calibration Procedure (see picture 1, page 4)

- 1) Unscrew the plug (P) and purge the system from air, shutting off the nozzle and let the pump running;
- 2) Reset the batch register by means of the knob;
- 3) Dispense at the flow rate which the best accuracy is required at, by using a calibration container having a capacity not lower than 20 litres.
- 4) Compare the indication of the calibration container (real value) with the one of the meter (indicated value):
 - a) if the indicated value is higher than the real value, turn counterclockwise the screw (H), using a screwdriver (S);
 - b) if the indicated value is lower than the real value, turn clockwise the screw (H), using a screwdriver (S);
- 5) Repeat the operation 3 and 4 until accuracy is satisfactory.
- 6) At the end of the procedures, screw the plug (P).

USE

After installation and calibration, if any, FM4 meter is ready to work.

Turn the reset knob clockwise until the batch register is completely reset (0000). The totaliser cannot be reset in any way. Make sure that during the use the pressure and flow rate do not exceed the values indicated in "Technical Data" section.

Use by gravity

FM4 can also be used in fuel units which are not equipped with pumps, where the flow is generated by fuel level difference between tank and nozzle outlet. As a reference, a system composed of a tank off the ground, with the meter installed right at the bottom of the tank, a three meter long 1" section flexible hose, guarantees a flow rate of approximately 30 liters/min., if the difference in level is higher than 1.5 meters. Longer pipes or nozzles producing higher pressure losses, reducing the flow in respect to the existing difference in level. Use by gravity is not recommended with differences in level lower than 1,5 meter, because of reduced flow that cannot ensure guaranteed accuracy. Calibration is always advisable in case of gravity installation.

MAINTENANCE - SPARE PARTS

No ordinary maintenance is required when the FM4 meter is properly installed and used. Anyway, an incorrect filtering on the meter inlet may block or wear out the measuring chamber, thus affecting the meter accuracy. Should this problem occur, disassemble the measuring chamber as indicated below.

WARNING! before disassembling the meter always make sure that all fluid is drained from the meter and pipes connections.

The FM4 meter can be disassembled without remove the main body from the pipes.

To disassemble the meter unit, follow this steps:

- 1) Remove the reset knob by firmly pulling it axially (see pos. 4, page 4);
- 2) Loosen the 4 retaining screws and remove the plastic cover (see pos. 3, page 4);
- 3) Loosen the 4 retaining screws and remove the counter (see pos. 2, page 4)
- 4) If is necessary replace the measuring chamber and /or the gear box, disconnect the pipes line and remove the complete hydraulics group (see pos. 1, page 4).

To reassemble the unit, reverse the above described procedure.

In the next page follows the explosion view of the counter and the spare parts list.

Exploded view

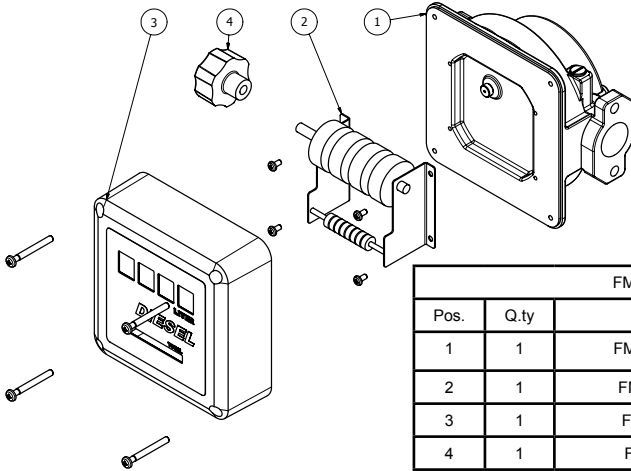

FM4 Spare parts			
Pos.	Q.ty	Description	P/N
1	1	FM4 Hydraulic group	695008
2	1	FM4 Counter group	695009
3	1	FM4 Cover (black)	695010
4	1	FM4 Knob (black)	695011

Picture 1

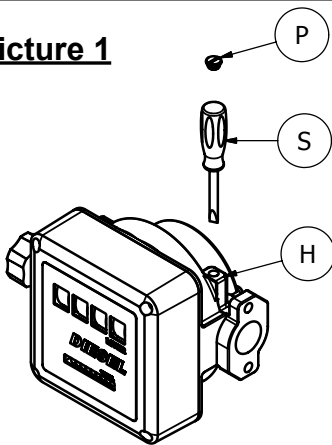

Dealer's Stamp

FLUID s.r.l.

Fuel Transfer Equipments

via G. Fucà, 119 ZI Torrazzi Sud
41100 Modena (MO) Italy

Tel. +39 059 250307

Fax +39 059 250307

e-mail: info@fluiditalia.it

www.fluiditalia.it



Pictures and descriptions are FLUID srl properties. Technical datas and characteristics indicated are intended not binding and FLUID srl could change them without any advanced notice.